

## Test Case 3 – Half wall

Test Description: It is common to have a half wall in a space. The half wall are usually smaller walls what serves as a partition, but not completely disconnect two spaces. Technically a half wall can be any height short of the ceiling but they are typically about 3' to 5' tall, depending on the wall's purpose and location. The test case provides a standard interpretation of such structure in the gbXML and a guideline to verify whether the BIM software can correctly export a space with a half wall

### Spaces / Rooms:

There is just one spaces in this test model. It is located at the first floor, named as “level\_1\_space\_1”.

### Special Considerations:

1. The model is 10'8” x 10'8” (outer line)
2. A 5' half wall is located in the center of the space with a thickness of 8”.
3. All the walls face to an orientation shall be named as: “[orientation]\_wall\_[custom index]”
4. All the other surfaces shall be named as their function, such as “interior\_wall\_[custom index]”
5. The custom index is an index to differentiate the same type surfaces. The tester can decide how to label the custom index.

### Description of Test Case:

**Figure 1** shows a 3-dimensional isometric view of this test model. Walls locates between the slab floor and the roof.

**Figure 2** shows a typical floor plan to indicate dimensions and directions of the space, with wall thickness.

**Figure 3** shows a typical section view to indicate positions and dimensions of the interior wall, the height of the roof.

The test case exported in gbXML model has a dimension of 10' x 10' x 10'.

The test case expects the half wall is translated into a shade inside the house.

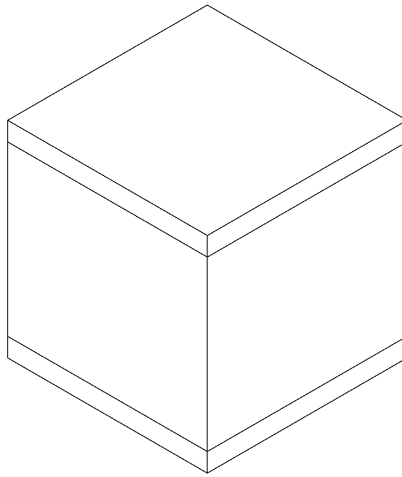

**Figure 1. Isometric View**

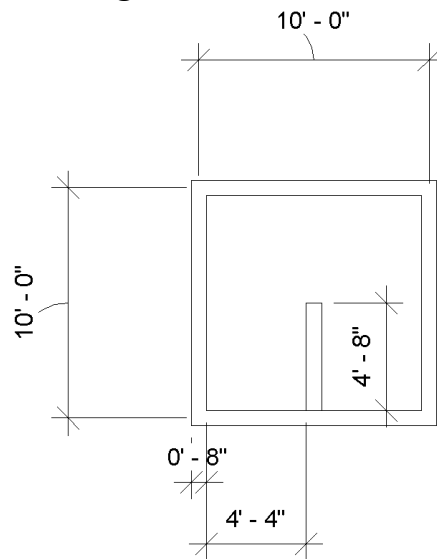

**Figure 2. Floor View**

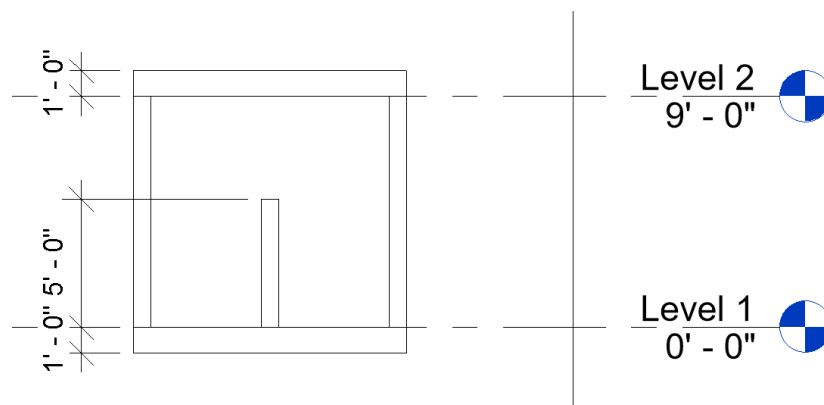

**Figure 3. Section View**

Common Outcomes and Test Results:

The most common issue occurred in this test is extra shading surfaces generation. The outside perimeter of the roof and interior wall becomes shading surfaces. The height of the space was 9' in the BIM model and becomes 10' in gbXML, as shown in **Figure 4**.

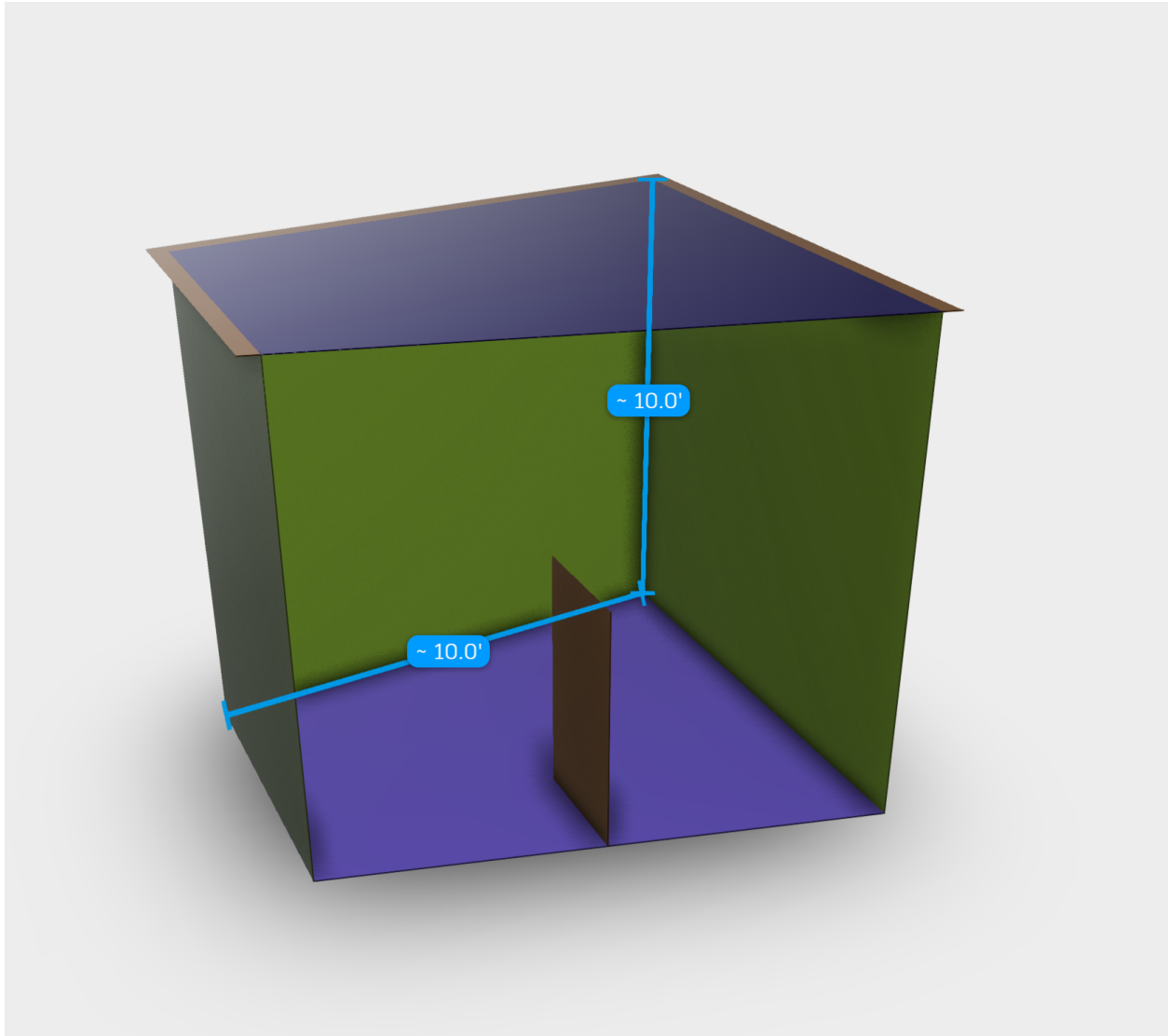

**Figure 4.** Surface Type Issue